

# Insul-8 Mobile Electrification

◆ Cable & Hose Reels ◆ Conductor Bar ◆ Festoon ◆ Pendants ◆  
◆ Radio Controls ◆ Slip Rings ◆

*Solutions From A Single Source*

## Cluster Bar Conductor Bar Systems



For the Electrification of:

- Cranes
- Monorails
- Automated Storage and Retrieval Systems



[www.insul-8.com](http://www.insul-8.com)

# About Insul-8

## Your Single Source for Mobile Electrification



Since our inception in 1902, Insul-8 Corporation's parent company, Delachaux S.A., has been a leading international presence in the business of providing mobile electrification. As the Delachaux arm in North and South America, Insul-8 Corporation (formerly sister companies Insul-8 and Industrial Electric Reels, Inc. - a.k.a. IER) carries on this tradition of innovation and excellence. Insul-8 and IER became part of the Delachaux Group in 1975 and officially became one company on December 31, 1996. Each company has its own rich history.

*You'll find Insul-8 products in use everywhere from irrigation systems and manufacturing plants in the heartland of the United States to public transportation systems in Malaysia.*

**Industrial Electric Reels, Inc.**, began in 1924 with the founding of Industrial Electric Works (IEW), an electrical contractor based in Omaha, Nebraska. After World War II, IEW began the manufacture of electric cable reeling equipment and started IER as an operating division in 1948. IER's first cable reel, the hand rewind Series 102 PORT-O-REEL, was quickly followed by light-duty spring retractable cable reels. IER pioneered the development of cable reeling devices and slip rings. Soon the business expanded to larger, custom built motor driven reels and custom engineered slip rings. IER's reputation spread as a quality manufacturer of reels running the gamut from small commercial duty reels to large custom built reels for the most demanding applications such as container cranes, stacker/reclaimers and bulk material ship loaders and unloaders.

**Insul-8 Corporation** has been a pioneer in providing safety-covered metal conductor systems for the material handling industry since 1944. Insul-8 was the first company to design and produce a stainless steel capped aluminum conductor and the only manufacturer of such a product for almost 20 years. Today, there are over 20 million meters (nearly 12,500 miles) of Insul-8 contact conductors and tens of thousands of collecting devices throughout the world. Every major port in the United States currently uses Insul-8's aluminum/stainless steel contact conductors on container cranes due to the dependability of the bar under the most severe conditions. Insul-8's festoon systems range from the smallest box-track systems to our most rugged Heavy-Duty Festoon. Insul-8's festoons are known for their safe and efficient operation in which large numbers of conductors can be handled in minimum space.

Insul-8 has been in the business of supplying power from stationary sources to mobile systems for 60 years. Insul-8's cable reels, slip rings, conductor bar, festoon systems, pendants and radio controls are used in a wide variety of applications ranging from material handling and mass transit systems to water treatment plants and performing arts theaters.

As it has been for the last 60 years and always will be, "conducting" business will continue to be our only business.

In December 1997, after a nine month endeavor, Insul-8 Corporation became ISO 9001 certified for the design and manufacture of our entire line of mobile electrification products in both of our U.S.A. plants in Omaha, Nebraska, and Harlan, Iowa.

- ◆ cable and hose reels ◆ conductor bar systems ◆ cable festoon systems ◆
- ◆ slip rings ◆ pendant stations ◆ radio controls ◆

[www.insul-8.com](http://www.insul-8.com)



Specifications may change without notice. All products F.O.B. Omaha, NE, or Harlan, IA, unless otherwise specified.

# Table of Contents

Cluster Bar Components and Definitions.....	3
Selecting a System.....	5
Cluster Bar Components.....	6
Hanger and Anchor Clamps.....	10
Brackets.....	11
Collectors.....	12
Curves and Slip Rings.....	13
Engineering Data.....	14
Special Notes.....	15

**Specifications May Change Without Notice.**

## Cluster Bar Standard Features

- UL listed and CSA approved
- Engineered for a confined space with 3/4" conductor spacing
- Captive "V" contact surface for positive tracking of collector shoe
- Certified to International Protection, IP2, standards
- Available with crimped or bolted connections
- Insulated PVC covering rated at 160° F
- Fast and easy to install
- Easy to maintain
- Operates in lateral or vertical mount using the same components
- Operational speeds through 600 fpm
- Easily curved in both the horizontal and vertical planes

**Don't see what you need? Call us!**

**Page 2**

# Cluster Bar Components

## Cluster Bar Typical 4 Conductor System

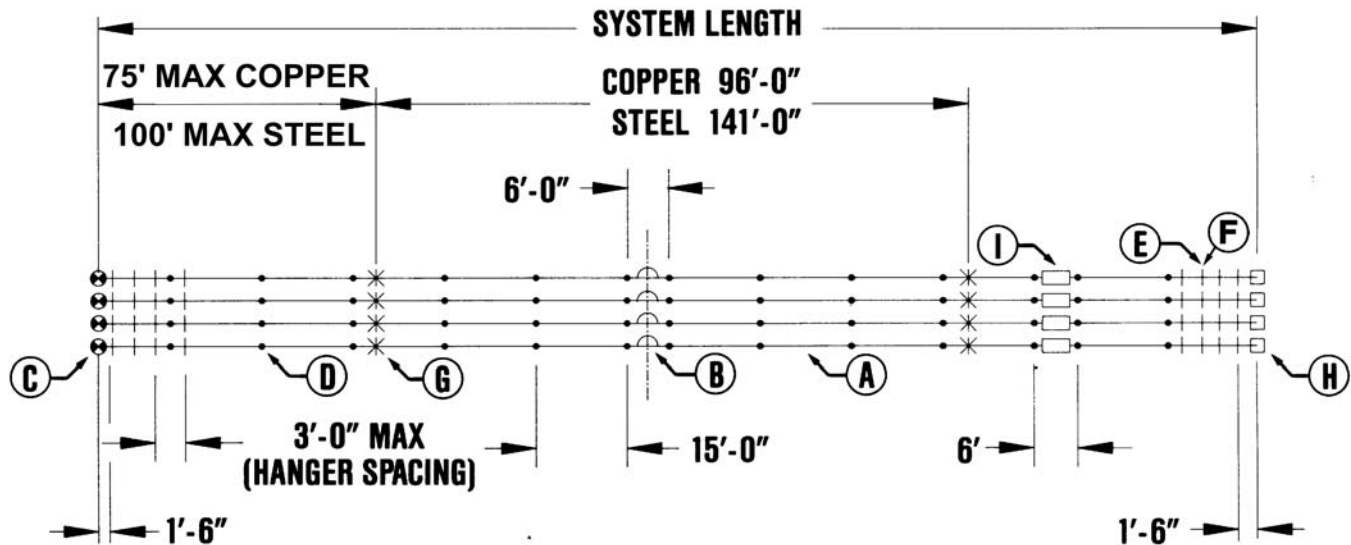

**NOTE:** MAXIMUM LENGTH W/O EXPANSIONS  
 120 AMP COPPER IS 150'  
 40 AMP STEEL IS 200'

A	Conductor Section 15 foot length.....	See Page 5
B	Expansion Section 6 foot length.....	See Page 5
C	Powerfeed.....	See Page 5
D	Splice Joints.....	See Page 7
E	Hanger Clamp.....	See Page 9
F	Multi Conductor Brackets.....	See Page 9
G	Anchor Clamp.....	See Page 9
H	End Cover.....	See Page 6
I	Isolation Section.....	See Page 8
J	Collector (Not Shown).....	See Page 11
K	Collector Mounting Staff (Not Shown).....	See Page 11

# Selecting the Correct System

## Selecting a System is Simple

To assist you in selecting a Cluster Bar system, answer the following questions.  
Return via fax and we'll provide a quote and qualified customer support.

1. Type of system (Runway, Bridge, Monorail, Other) \_\_\_\_\_
2. Length of System (Ft.) \_\_\_\_\_
3. Number of Conductors \_\_\_\_\_
4. Number of Vehicles (cranes, etc.) \_\_\_\_\_
5. Voltage \_\_\_\_\_ AC \_\_\_\_\_ DC
6. Amperage requirement of each vehicle \_\_\_\_\_ (pg. 14)
7. Total ampacity required \_\_\_\_\_ (pg. 14)
8. Ambient temperature: (if other than -10°F. to +160°F.) \_\_\_\_\_ to \_\_\_\_\_
9. Atmosphere: Dry \_\_\_\_\_ Dusty \_\_\_\_\_ Dirty \_\_\_\_\_  
Corrosive \_\_\_\_\_ Nuclear \_\_\_\_\_ Other \_\_\_\_\_
10. Bracket Required: Number \_\_\_\_\_ Web \_\_\_\_\_ Flange \_\_\_\_\_
11. Special Concerns: \_\_\_\_\_

### Need Assistance?

**Contact Insul-8 or your Local Representative Now!**  
**We'll be happy to quote your system**  
**or parts requirements for you.**

**Don't see what you need? Call us!**



# Cluster Bar Components

## Conductor Bar

Continuous roll formed inverted "V" cross section encased by an insulated PVC cover. Splice kit included with the price of conductor.

Operating Temperature:  
-10°F. to 160°F.

Bar Type	Bolted Splice Connection Part No.	Crimped Splice Connection Part No.	Length Ft.	Approx. Weight
Galvanized Steel 40 amp.	28656	28101	15	2.0
Rolled Copper 120 amp.	28655	28100	15	2.0

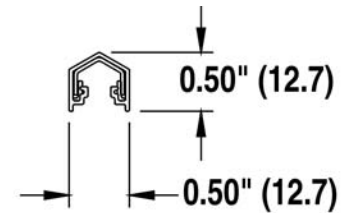
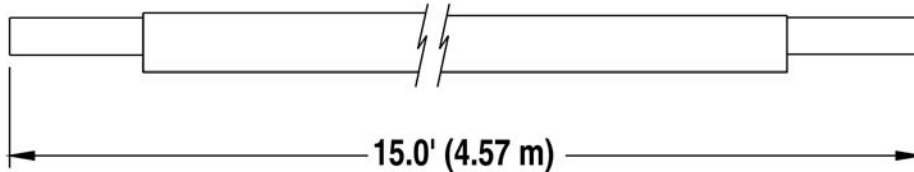

## Expansion Section

Factory assembled with overlapping design to provide continuous contact with collector shoes. Powerfeeds and flexible jumpers are installed to meet electrical and mechanical requirements. Please refer to Page 3 for location details. Splice kit included with the price of expansion.

Bar Type	Bolted Splice Connection Part No.	Crimped Splice Connection Part No.	Length Ft.	Approx. Weight
Galvanized Steel 40 amp.	28658	28104	6	6.0
Rolled Copper 120 amp.	28657	28103	6	7.0

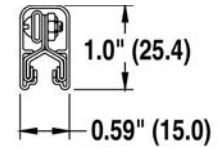
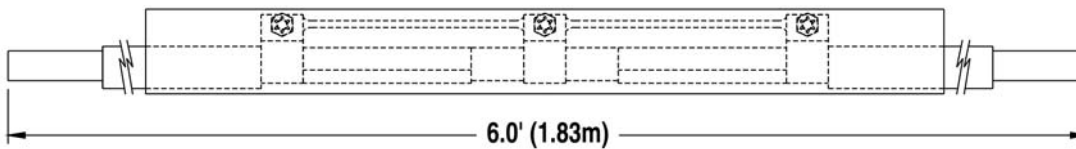

## Powerfeed

Provides the electrical connection from power source to the conductor bar. It may be located at any point along the conductor, preferably near the system's center to reduce voltage drop.

Part No.	Connection Wire Size	Approx Weight
28067	#10 AWG	.4
28066	#6 AWG	.4

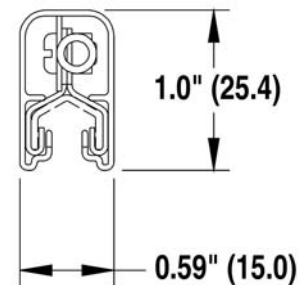
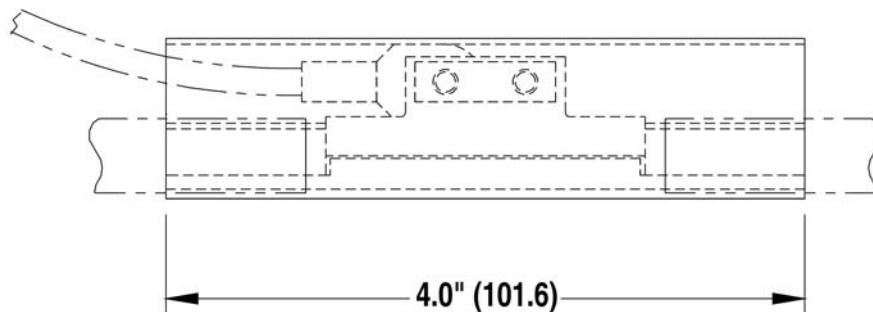

# Cluster Bar Components

## End Power Transfer

Part No.	Connection Wire Size	Approx Weight
29836	#8 AWG	.2
29837	#10 AWG	.2

Provides the electrical connection from the power source to the conductor bar. This powerfeed attaches to the end of the bar.

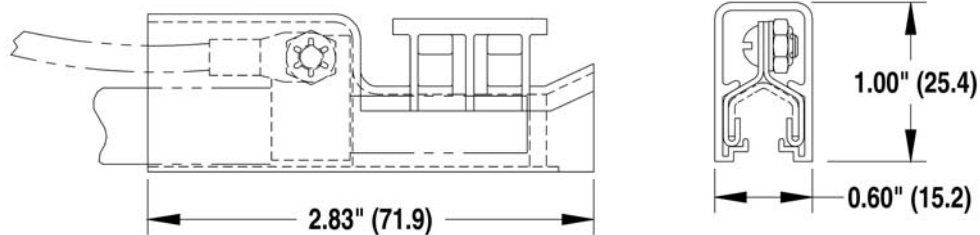

## End Cover

Part No.	Approx Weight
28105	.3

Two piece polypropylene boot used to close off the open ends of the conductor bar.

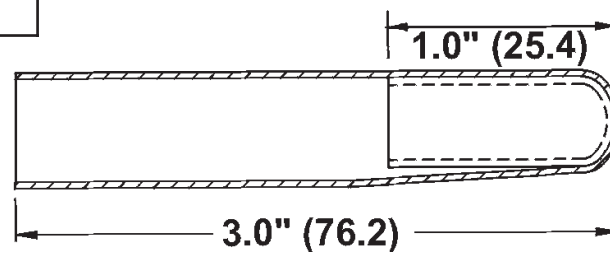

## Crimping Tool

Part No.	Approx Weight
28102	5.0

Used to join the crimp style bars together.

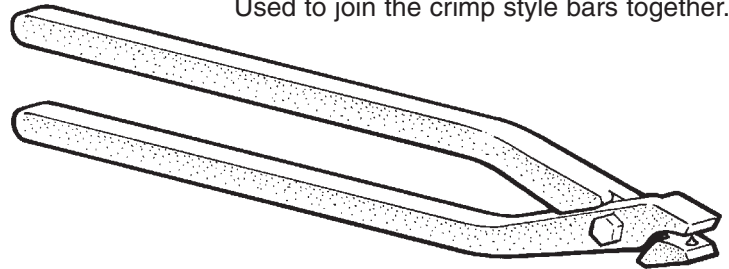

## Splice Cover Kit

Part No.	Approx Weight
29875	5.0

Insulates the bar joint.

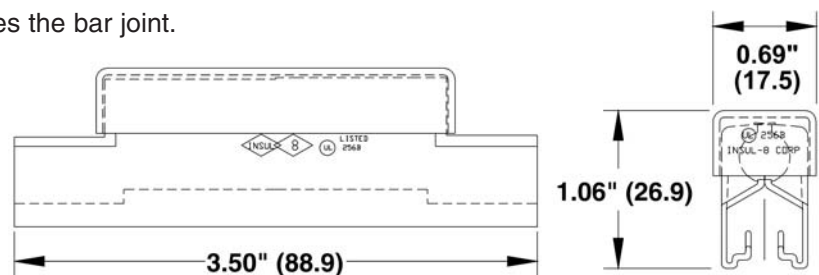

**Don't see what you need? Call us!**

**Page 6**

# Cluster Bar Components

## Splice Kits

Connects two sections of conductors together

Bar Type	Bolted Splice Connection Part No.	Crimped Splice Connection Part No.	Approx. Weight
Galvanized Steel 40 amp.	29632	30211	.20
Rolled Copper 120 amp.	29548	30210	.20

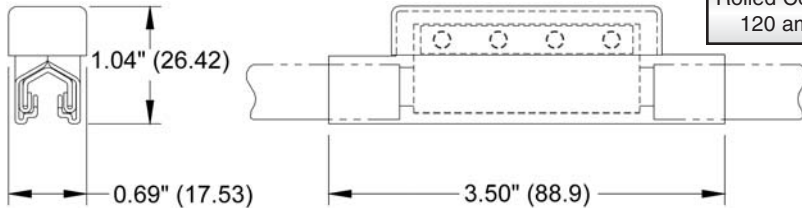

## Transfer Cap

Used to guide the contact shoe through a 1/4" maximum air gap.

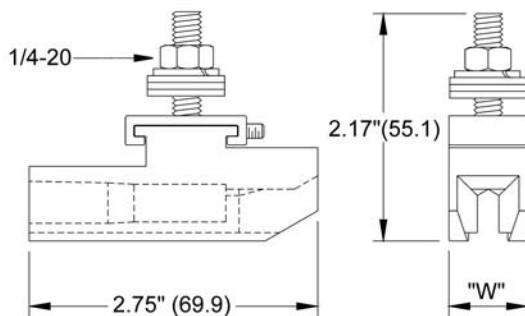

Part No.	No. Cond.	"W"	Approx. Wt.
29413	1	.60	.10
28807	3	1.80	.30
28808	4	2.40	.40
28809	5	3.00	.50
28810	6	3.60	.60

## Pick-Up Guides

Scoop located at the end of the conductor. Designed to gather the collectors and align them to ride on the conductor bars for discontinuous operation. Consult factory for proper selection.

Part No.	No. Cond
30656	2
34808	3
28127	4

## Isolation Sections

Manufactured for electrical separation within the electrification system. These sections are factory assembled with transfer caps and mechanically aligned brackets to effortlessly guide the contact shoe through air gaps. Power clamps are part of the 6-foot section enabling a separate electrical connection. Splice kits included with the piece of isolation.

Bar Type	Bolted Splice Connection Part No.	Crimped Splice Connection Part No.	Length Ft.	Approx. Weight
Galvanized Steel 40 amp.	29833	29935	6	2.0
Rolled Copper 120 amp.	29832	29936	6	3.0

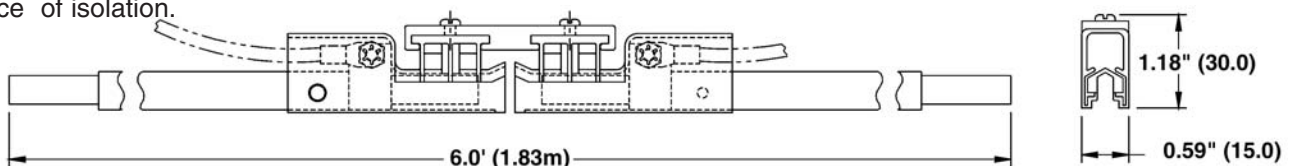



# Cluster Bar Components

## Isolation Kit

Part No.	Connection Wire Size	Approx. Wt.
28126	#10 AWG	.5
29869	#8 AWG	.5

Provides isolation between conductor bar.

**\*Wire not included.**

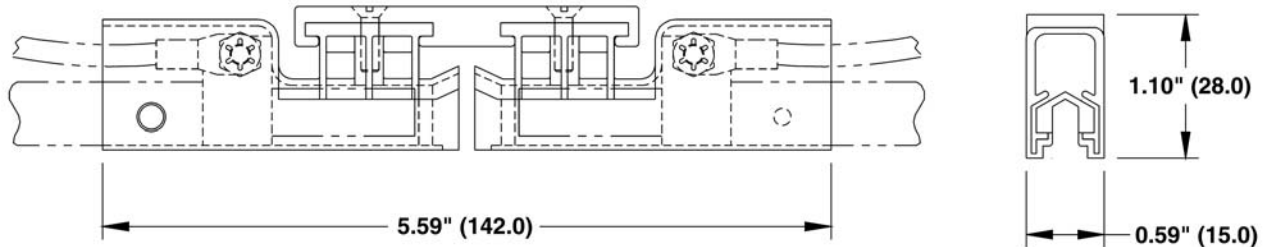

## Power Interrupting Sections

Bar Type	Bolted Splice Connection Part No.	Crimped Splice Connection Part No.	Length Ft.	Approx. Weight
Galvanized Steel 40 amp.	29835	29937	6	5.0
Rolled Copper 120 amp.	29834	29938	6	5.0

Manufactured for electrical separation with an on/off zone in a length greater than the tandem collector. These sections can be electrically turned on or off with a manual switch (not normally provided). The isolation at each end of the on/off zone is factory assembled with transfer caps and mechanically aligned brackets to effortlessly guide the contact shoe through air gaps.

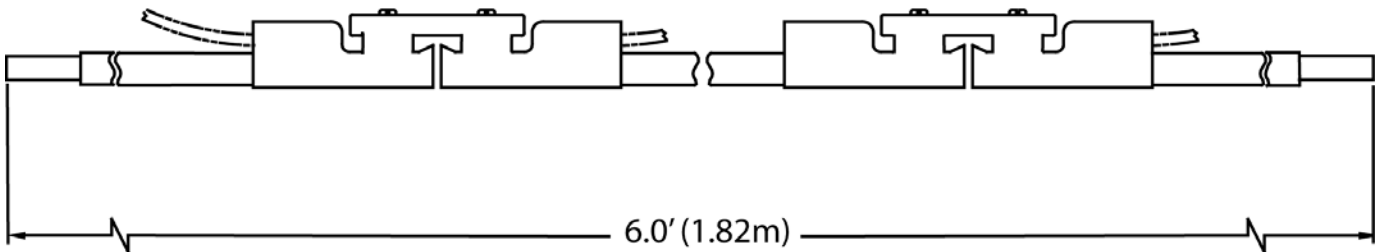

## Take Up Sections

Bar Type	Bolted Splice Connection Part No.	Crimped Splice Connection Part No.	Length Ft.	Approx. Weight
Galvanized Steel 40 amp.	29831	29933	6	5.0
Rolled Copper 120 amp.	29304	29934	6	5.5

Factory assembled plastic housing sections designed to guide the collector through the take up area and back onto the conductor. Consult factory for proper selection.

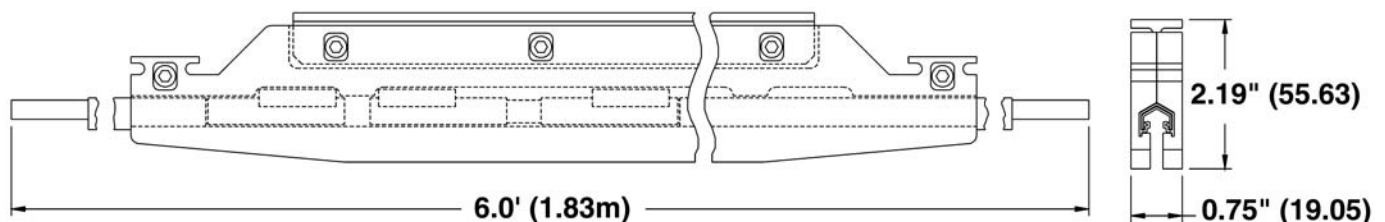

**Don't see what you need? Call us!**

**Page 8**

# Cluster Bar Components

## Hanger Clamps

Molded polycarbonate hangers designed for vertical or horizontal mounting. The hanger clamps “snap on” the conductor for a sliding fit.

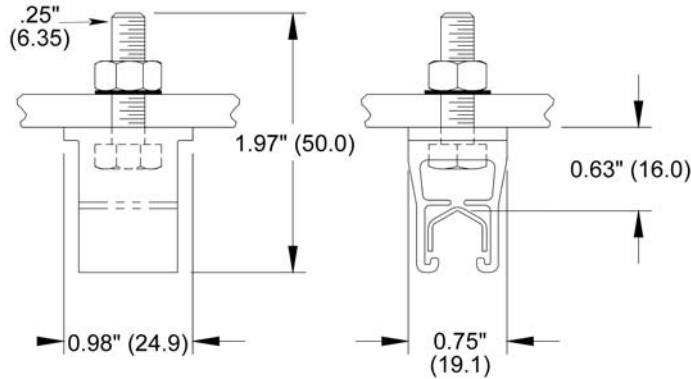

Part No.	Description	Approx. Wt.
28112	Hanger Clamp	.20

## Anchor Clamps

These are molded plastic pieces that are bolted together and are positioned on each side of the hanger clamp. The anchor clamps hold the conductor firmly while allowing thermal expansion and contraction. The kit includes two clamps per conductor.

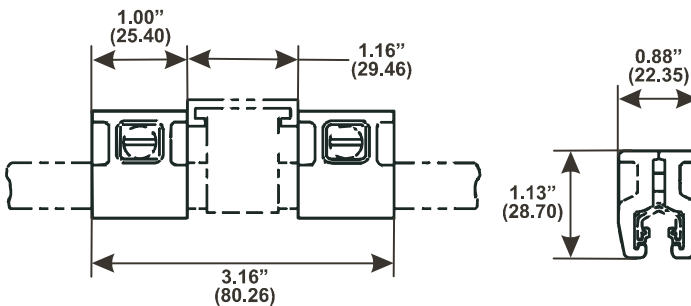

Part No.	Description	Approx. Wt.
29864	Anchor Hanger Clamp	.14

## Multi-Conductor Bracket

Molded bracket with hanger clamps. There is no need for an aluminum mounting bracket.

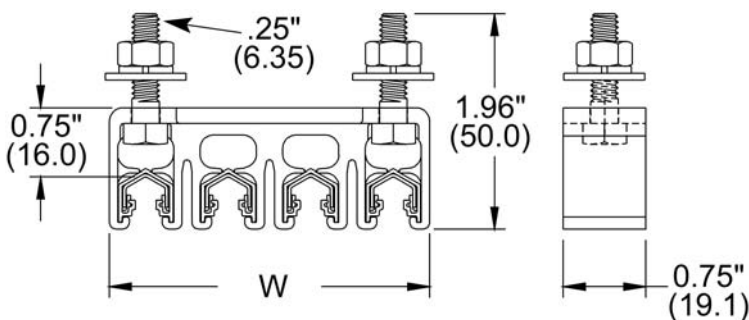

Part No.	No. Cond.	"W"	Approx. Wt.
33138	3	2.16"	1.0
33137	4	2.90"	1.1

# Cluster Bar Components

## Multi-Conductor Bracket

Aluminum mounting channel with hanger clamps, available in various conductor configurations.

Part No.	No. Cond.	"W"	Approx. Wt.
29475	2	1.50"	0.9
28113	3	2.14"	1.0
28114	4	2.85"	1.1
28115	5	3.56"	1.2
28116	6	4.28"	1.3
28806	7	5.25"	1.4

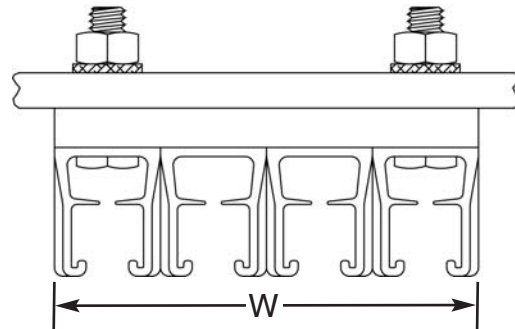

## Multi-Conductor Web Brackets

Aluminum channel web bracket with assembled hanger clamps in various conductor configurations.

Part No.	No. Cond.	"W"	Approx. Wt.
28665	3	2.25"	1.4
29939	4	3.00"	1.5
29940	5	3.75"	1.6
29941	6	4.50"	1.6

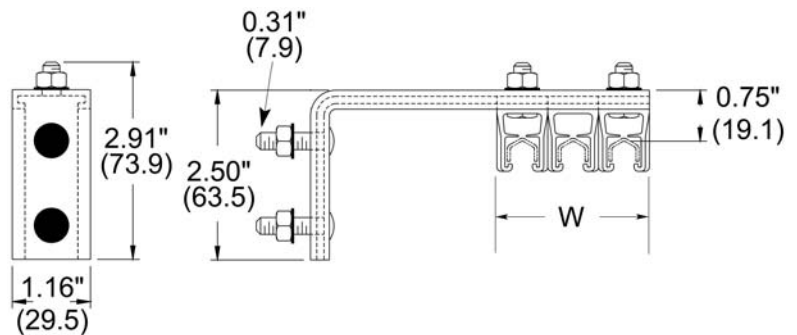

## Multi-Conductor Flange Bracket

Aluminum channel flange bracket with assembled hanger clamps in various conductor configurations. (Includes flange clips)

Part No.	No. Cond.	Bracket Setting	Approx. Wt.
28666	3	2/1	1.4
29942	4	2/2	1.5
29943	5	2/3	1.6
29944	6	2/4	1.6
29986	3	0/3	1.4
29987	4	0/4	1.6
29988	5	0/5	1.7
29989	6	0/6	1.8

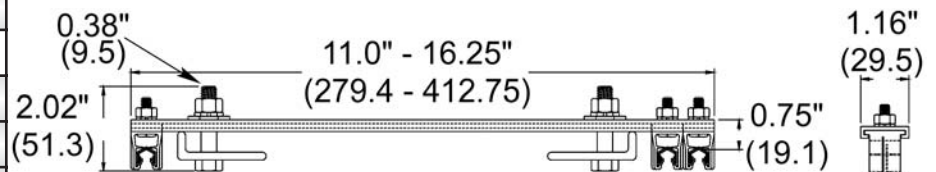

Don't see what you need? **Call us!**

Page 10

# Collectors

## 30 Amp. Collector, Single Conductor

### 1/2" Square Bar Mount Type.

Insulated contact head mounted on self centering, spring loaded arm that articulates in both the vertical and horizontal positions. Exposed metal surfaces do not carry current as mounts are grounded. The sliding contact type confines wear only to the easily replaceable contact shoes. Part #: 28082

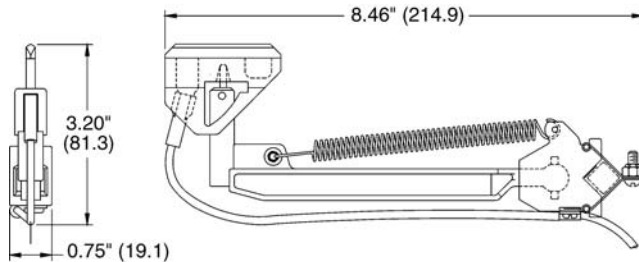

Part No.	Description	Approx. Wt.
31589	Single Pole Collector	.80

## 30 Amp. Collector, Multi-Conductor

### Channel Mount Type

Insulated contact heads mounted on self centering spring loaded arm assemblies that articulate in both the vertical and horizontal positions. Exposed metal surface does not carry current as mounts are grounded. The sliding contact type confines wear only to the easily replaceable contact shoes.

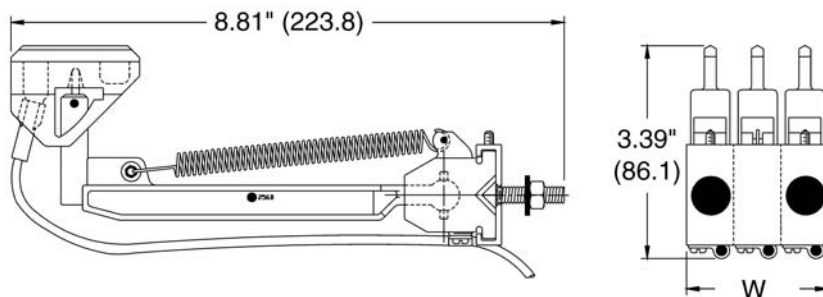

Part No.	No. Cond	"W"	Approx. Wt.
31799	2	1.50"	2.5
31583	3	2.25"	3.0
31584	4	3.00"	3.8
31585	5	3.75"	4.6
31586	6	4.50"	5.4

## 30 Amp. Compression Collector

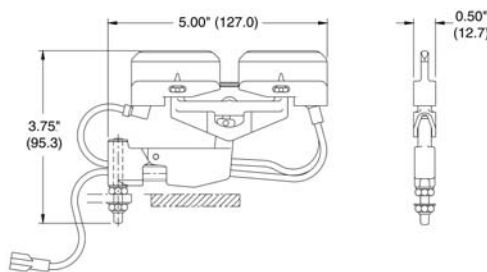

Part No.	Description	Approx. Wt.
32180	14mm, compression collector	1.6

## Staff Collector Mount

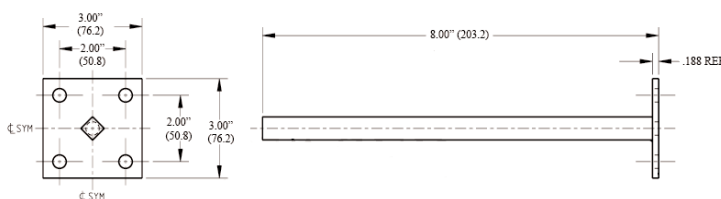

Used for mounting 31589 collector.

Part No.	Approx. Wt.
39618C	1.0

# Curves & Slip Rings

## Slip Rings

Factory supplied in 360° rings or segments to fit the mounting specifications. 16" minimum radius for inside or outside contact.

Description	Part No. 40 Amp.	Part No. 120 Amp.
1-piece 360° 16" Radius to 27" Radius	29960	29962
2-180° Pcs. 27.1" Radius to 54" Radius	29964	29966
3-120° Pcs. 54.1" Radius to 80" Radius	29968	29970

## Curves

Factory engineered curved systems available.

Description	Crimp Splice Connection Part No.	Bolted Splice Connection Part No.	Minimum Radius IN.
Horizontal Inside 40 Amp.	28503	29364	16
Horizontal Inside 120 Amp.	28500	29363	16
Horizontal Outside 40 Amp.	28504	29359	16
Horizontal Outside 120 Amp.	28501	29358	16
Vertical 40 Amp.	28505	29366	32
Vertical 120 Amp.	28502	29365	32

**\* Splice Kits included with price of Slip Rings & Curves.**

**Consult Factory for Assistance in Regards to your  
Curve and Slip Ring Requirements.**

## Curving Machine

Part No.	Description	Approx Wt.
29931	Curving Machine	25 lbs.

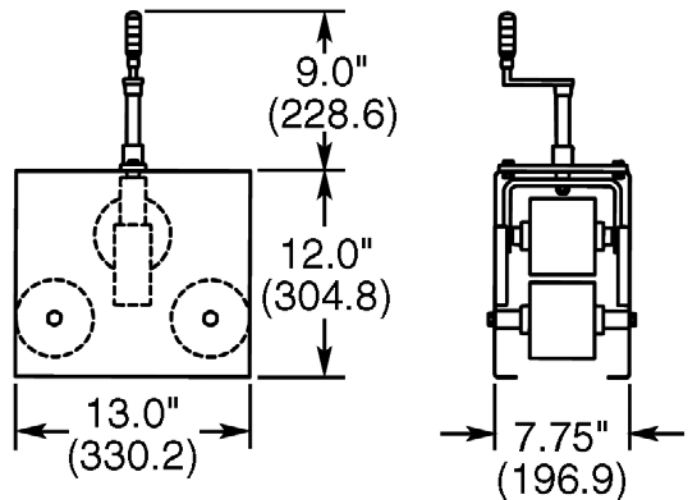

**Available for Lease or Sale.  
For in-field or on-site Curving of Cluster Bar**

**Don't see what you need? Call us!**



## Proper Selection

Proper selection of Cluster Bar contact conductor systems is simple, requiring only the ampacity, voltage and ambient conditions.

The method of determining the rating for cranes and hoist is completely outlined in NEC 610-14(e). Further references to the Code are made where applicable.

1. For single crane, simply use the name plate full load ampere rating of the largest motor or group of motors for any one function plus half the rating of the next largest motor or motor groups.

$$\text{Hoist} = 65a \times 1.0 = 65.0$$

$$\text{Bridge} = 27a \times 0.5 = 13.5$$

$$\text{Total} \quad \quad \quad \underline{78.5 \text{ amps.}}$$

2. When the motor ampere ratings are unknown, a good approximation may be made by using nominal hp ratings or the motors, converting them to full load amperes per NEC table 430-150 and proceeding as above.

A few examples from the tables are:

**Full-Load Current in Amperes, Direct Current Motors**  
**Armature Voltage Rating (Direct-Current)**

HP	240V
10	38
15	55
20	72
25	89
30	106

**Full-Load Current**  
**(Three-Phase Alternating-Current Motors)**

HP	230V	460V	575V
10	28	14	11
15	42	21	17
20	54	27	22
25	68	34	27
30	80	40	32
40	104	52	41
50	-	65	52
60	-	77	62
75	-	96	77
100	-	124	99

## How to Figure Voltage Drop

“The arithmetical difference between the voltage at the feed point and the load extreme end.” It is usually expressed as a percentage of the supply voltage and can be calculated as shown below. Voltage drop increases in direct proportion to the length of conductors. The Electrical Overhead Crane Industry specifications limit total voltage drops to 3% on runways and 2% on bridge conductors. Since powerfeeds are usually located at the mid-point of a system. The effective length is the distance from powerfeed to the end of the runway. On longer systems it may be necessary to provide additional feedpoints.

### Voltage Drop per 100 feet of run per 100 Amps of Current

Conductor	3Ø 60HZ	@3% 480 VOLTS
Steel	40.1	90 Ft.
Copper	4.1	293 Ft.

**Example:**  
Copper conductor 250 feet,  
60 amp. load,  $VD = 4.1 \times 2.50 \times .60 =$   
6.15 volts = 1.3% VD

Conductor	Ampacity	Resistance R (DC)*	Reactance 60HZ 30*	Impudence z (60HZ)*	Spacing
Steel	40 Amp.	2382	382	2412	3/4"
Copper	120 Amp.	245	38	248	3/4"

\*Micro-Ohms Per Foot

## Typical Installation Details

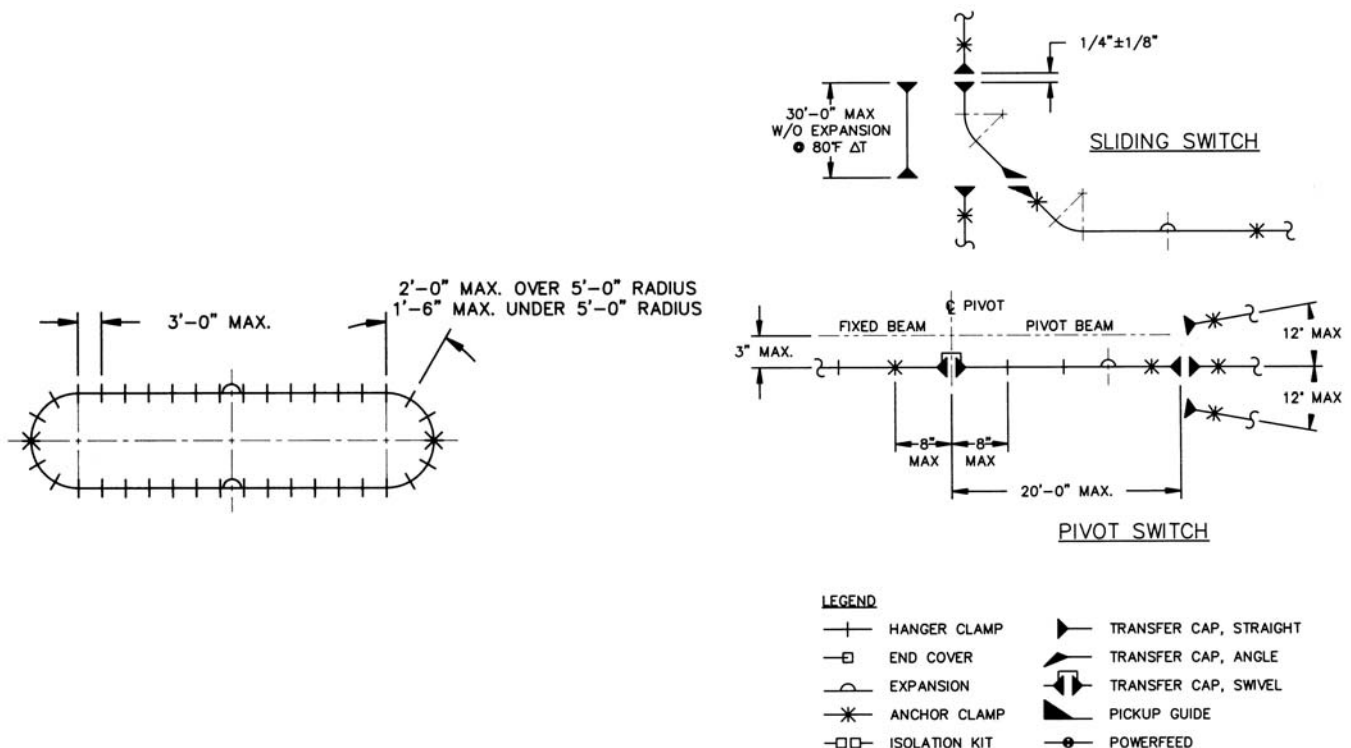

Don't see what you need? **Call us!**

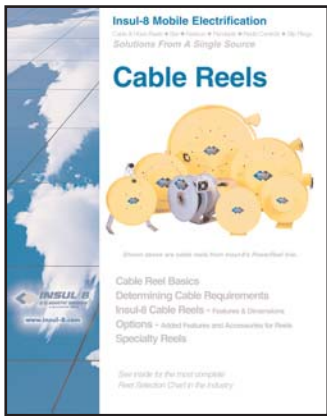

SPRING DRIVEN REELS



CONDUCTOR BAR

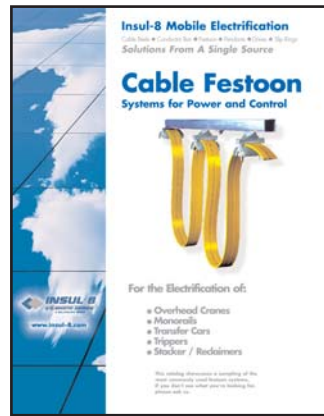

FESTOON

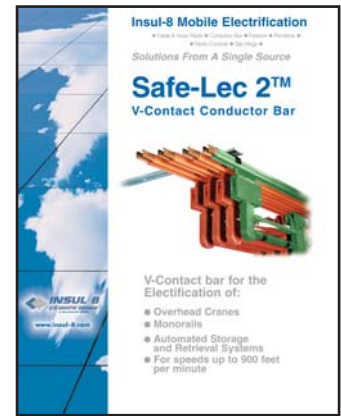

CONDUCTOR BAR

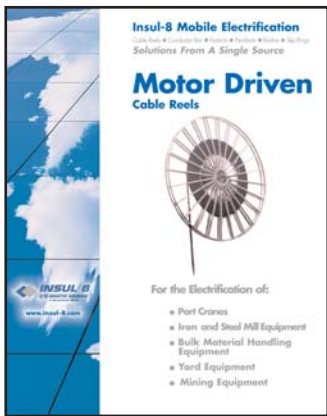

MOTOR DRIVEN REELS



Please visit our website at:  
[www.insul-8.com](http://www.insul-8.com)

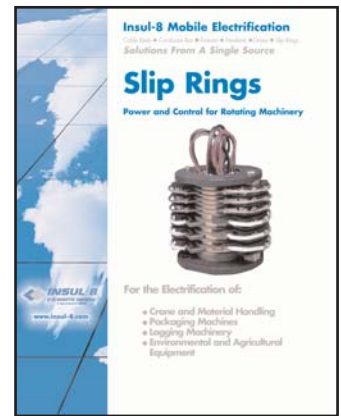

SLIP RINGS

USA

10102 F Street Omaha, NE 68127  
Phone: (402) 339-9300 Toll Free: (800) 521-4888  
Fax: (402) 339-9627 Toll Free: (800) 780-8329  
e-mail: [i8-info@insul-8.com](mailto:i8-info@insul-8.com)

CANADA

175 Boulevard J.F. Kennedy  
St. Jerome, Quebec J7Y 4B5  
Phone: (514) 565-9900  
Toll Free: (800) 667-2487  
Fax: (514) 432-6985  
e-mail: [contact@insul-8.com](mailto:contact@insul-8.com)

MEXICO

Puerto La Paz #123 Col. La FE,  
San Nicolas de los Garza,  
N.L. C.P. 66477  
Phone: (81) 1090-9013  
Fax: (81) 1090-9014  
e-mail:

AUSTRALIA:

14 England Street  
Dandenong, Victoria 3175  
Phone: (3) 9706 88 44  
Fax: (3) 794 92 98  
e-mail: [info@insul-8.com.au](mailto:info@insul-8.com.au)